



The First Name In Bakery



Adamatic ARDS-55 Reversible Dough Sheeter

STANDARD FEATURES

- 23.6" wide working path
- Belt length 55" per side
- 3" easy to adjust rollers
- Quiet V-Drive belt motor
- Polyurethane belt
- Hand and foot reverse controls
- Epoxy coated food grade exterior
- Mobile on castor base w/levelers
- Easy to clean removable non-stick scraper blades
- Food grade plastic flour container
- S/s safety guard

ACCESSORIES

- 2-Speed cutting attachment (Model ARDS-55LT)
- Left of right side mount (must specify)
- Cutters for ARDS-55LT (consult factory)



The First Name In Bakery

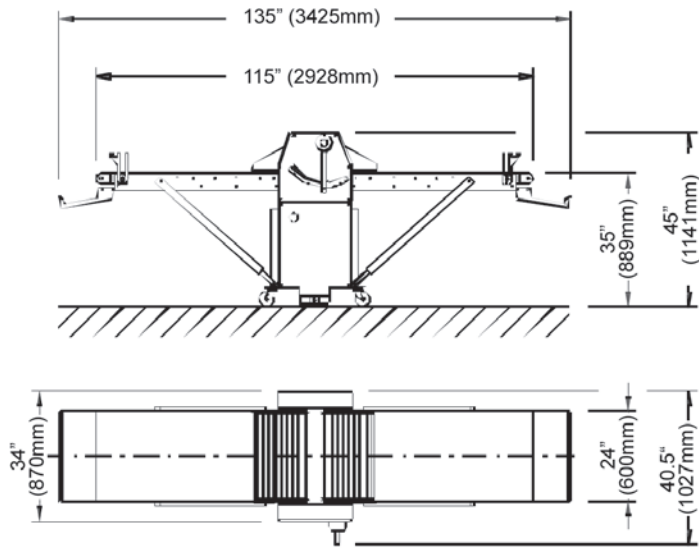

Model	ARDS-55
Dimensions	
Overall width	135" (3425 mm)
Overall height	45" (1141 mm)
Overall depth	40.5" (1027 mm)
Belt width	24" (600 mm)
Belt length per side	55" (1397 mm)
Electrical	
Volts	240V/60/3
Amps	3.2 A
Watts	750 W