

Industrial bread line stainless steel



Stainless steel heavy-duty bread line. All machines are designed for continual bread processing and are well known for high quality materials, reliable availability and excellent baking results. The line has a capacity of up to 3000 pcs/hour. All machines are produced in Sweden according to CE-regulations.

SDG



Sveba Dahlen Group

SVEBA
DAHLEN



Gimek
baking system

Scandinavian know-how – worldwide

Industrial bread line stainless with MO-360

SD-300 Suction dough divider



- Stainless steel
- PLC control with touch screen
- Frequency controlled drive
- Very accurate scaling
- Easy to convert between 1-pocket and 2-pocket drive

Options:

- Non-stick coated hopper
- Flour duster
- 59.5 US gal hopper
- Outfeed roller for sticky dough

| | | SD 300 | SD 300 XL |
|--------------|-----------|--------------------|-----------------|
| Weight range | 1-pocket | 3.5 oz - 2.2 lb | 8.8 oz - 5 lb |
| Weight range | 2-pockets | 1.4 oz - 14 oz | 5.3 oz - 2.5 lb |
| Capacity | 1-pocket | 750-1500 pcs/hour | |
| Capacity | 2-pockets | 1500-3000 pcs/hour | |

CR-310GM Conical rounder



- Stainless steel
- Centrally adjustable tracks
- Non-stick coated cone and tracks
- Rounding length up to 13 ft
- Patented

Options:

- Frequency converter
- Flour duster
- Cold/hot air blowing unit.
- Outfeed conveyor
- Outfeed roller for sticky dough

| | |
|--------------|---------------------|
| Weight range | 1.05 oz - 4 lb |
| Capacity | Up to 3600 pcs/hour |

IPP Intermediate pocket proofer



- Stainless steel
- Non-stick coated transfer box
- Double infeed V-belt conveyer
- Electric control panel
- Central electric cabinet

Options:

- Reversible outfeed conveyer
- Humidification system
- Modular system, up to 940 pockets
- UV-light

| | |
|--------------|---------------------|
| Weight range | 3.5 oz - 3.3 lb |
| Capacity | Up to 3000 pcs/hour |

MO-360 Industrial Moulder



- Stainless steel
- State of the art Moulder for industrial bakeries
- Exact settings via servo motors on infeed system, rollers, pressure board and side guides
- Separate drives on sheeting and moulding station
- Gives the products almost seamless closure

Options:

- No options, all included

| | |
|--------------|---------------------|
| Weight range | 1.05 oz - 4 lb |
| Capacity | Up to 3600 pcs/hour |

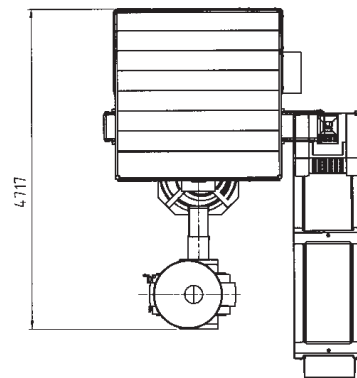
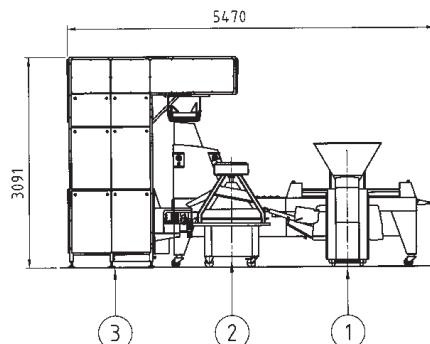
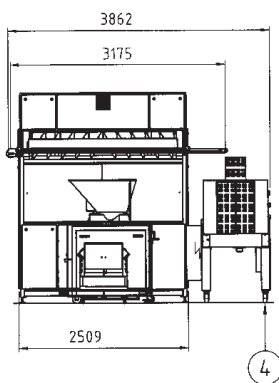

1. SD-300
2. CR-310 GM
3. IPP
4. MO-360



Glimek AB

P.O. Box 124 • S-280 64 GLIMÄKRA • Sweden
 Phone +46 44 449 00 • Fax +46 44 449 10
 e-mail: office@glimek.se • www.glimek.se



Belshaw Adamatic Bakery Group
 814 44th St NW
 Suite 103
 Auburn Washington 98001
 USA
 Phone: +1 732 544 8400
 Fax: +1 732 544 0735