

CR-260 Cone Rounder



Glimek CR-260 is a conical rounder designed for a wide range of products. Fixed tracks set for different weight ranges gives an excellent pre-rounding as well as final round moulding.



Sveba Dahlen Group



Scandinavian know-how – worldwide

CR-260 Cone Rounder

Rounding length up to 13 ft

Non-stick coating on tracks for ultimate rounding.
CR260GM version: Non-stick coating also on the cone



The laminated baseplates are machined to fit the cone for minimum dough loss



Adjustable tracks with pre set baseplates

Accessories

Flour duster	Flour duster, mechanical mounted on the outfeed
Hot and cold air blowing unit	Air blowing on the cone to assure the handling of sticky dough. 2.8kW
GM-version	Glim Metallic non-stick coating on cone
Oiling device	Photocell controlled oiling system with 3 spraying nozzles spraying on the products. (An alternative to Hot and cold air blowing unit)
Outfeed cone	Small driven upside down cone to ensure transfer of sticky dough from last track onto the outfeed conveyor
Outfeed conveyor including transfer roller	Replaces the outfeed chute. L = 23 5/8" with separate motor drive 0.09kW
Stainless steel version	Stainless steel frame and covers
Variable cone speed	Frequency controlled drive with speed regulator on the machine head, 1.5kW, 18-73 rpm (Standard is 46 rpm)
Variable cone speed including hot and cold air blowing unit	Frequency controlled drive with speed regulator on the machine head, 2.8 kW 18-73 rpm (Standard is 46 rpm) Airblowing on the cone to assure the handl. of sticky dough

Technical data

Capacity range	up to 3600 dough-pieces/hour
Weight range CR-260/1	1.4 - 17.6 oz
Weight range CR-260/2	13.4 oz - 2.2 lbs
Weight range CR-260/3	28.2 oz - 3.3 lbs
Weight range CR-260/4	2.5 - 3.8 lbs
Weight range CR-260/5	3.3 - 4.4 lbs
Power supply	1,5 kW
Weight, net	900 lb
Weight, gross (carton+pallet)	1190 lb
Volume, gross	4.5 x 4.4 x 5.5 = 108.9 ft ³

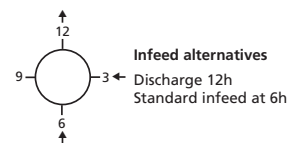
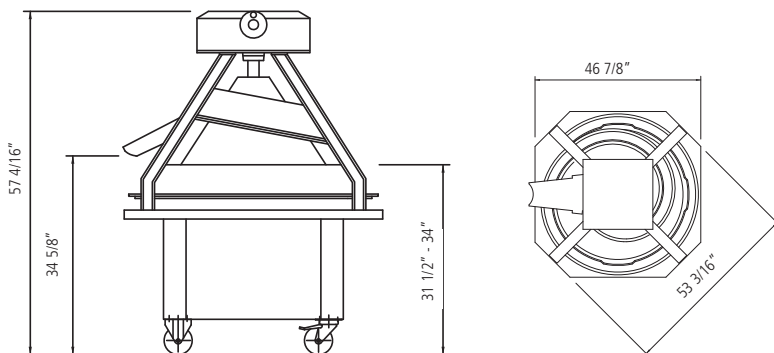

Glimek AB
Box 124
S-280 64 GLIMÅKRA
Sweden
Tel. int. +46-(0)44 449 00 • Fax +46-(0)44 449 10
e-mail: office@glimek.se • www.glimek.se



Belshaw Adamatic Bakery Group
814 44th St NW
Suite 103
Auburn Washington 98001
USA
Phone: +1 732 544 8400
Fax: +1 732 544 0735